

5500-Series API Coupler

EXCLUSIVE
5-YEAR
MECHANICAL
WARRANTY*



The Right Connection®

Application

- Combined with API adapters, these couplers are suitable for rail car and tank truck loading or unloading

Features

- Locking five-cam design provides easy alignment and tight connection
- Modular design allows various face seal combinations to be compatible with different alternative fuels, performance levels, and applications
- Replaceable nose seal can be changed without removing coupler from loading arm
- Fully interlocked collar prevents fitting from opening when disconnected and from being disconnected while opened
- 4" TTMA inlet mounting flange connection
- Ball-end handle for easy and comfortable operation
- No special tools needed for maintenance

Materials

- Body: 356 T6 aluminum anodized hard-coat
- Cam: stainless steel
- Poppet: 356T6 aluminum anodized hard-coat
- Seals: FKM-GFLT standard; Baylast, EPDM, Fluoroelastomer, FKM-B, HiFluor®
- Link, shaft, pin, crank: hardened 17-4PH stainless steel
- Handle: aluminum, stainless steel

Specifications

- Seal operating temperature:
 - Baylast: -35°F to 212°F (-37°C to 100°C)
 - EPDM: -20°F to 250°F (-28°C to 121°C)
 - FKM-B: -10°F to 400°F (-23°C to 204°C)
 - FKM-GFLT: -30°F to 400°F (-34°C to 204°C)
 - Fluorosilicone: -50°F to 350°F (-45°C to 176°C)
 - HiFluor: -15°F to 400°F (-26°C to 204°C)
- Flow rate: 600 GPM at 3 PSI pressure drop; max flow rate: 1,000 GPM
- Fully compliant with API RP1004:2003 specifications



Description	Part #
5500 API rack coupler FKM-GFLT aluminum handle	5500G
5500 API load coupler FKM-B seals with aluminum handle	5500B
5500 API rack coupler Baylast aluminum handle	5500BL
5500 API rack coupler EPDM aluminum handle	5500E
5500 API rack coupler Fluorosilicone aluminum handle	5500F
5500 API rack coupler HiFluor with aluminum handle	5500H

*Normal wear and tear items (including seals) not covered.

New Design Features



The Right Connection®

Seal Design

5300-Series

5500-Series

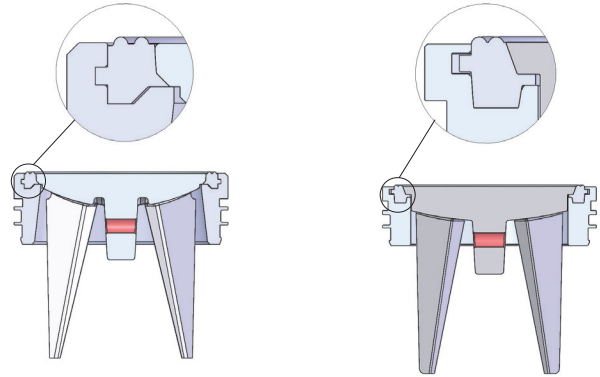

Improvement

- Removeable seal design is keyed in place and tested to **450 PSI** without seal ejection.

Benefit

- The new nose seals will handle a higher burst pressure of **450 PSI** in comparison to the **150 PSI** bonded nose seal.

Coiled Stainless Steel Springs

- 10 stainless steel coiled springs have been added. Coiled springs put more pressure on the nose seal-to-truck API adapter to help prevent leaks.

Benefit

- This will solve the occasional rusting and breaking issues that occurred using the carbon steel wave washer.

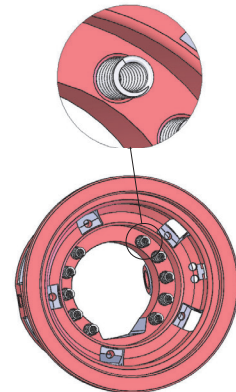

Two-Piece Handle

Improvement

- Two-piece handle is attached to the coupler with two separate cross pins.

Benefit

- Should the handle cross pins be sheared away, the interlock will remain operational, preventing the coupler from opening.

